

KRAUS STEDI-FLO™ Vibratory Pan Feeder



Excellent Performance and Reliability

The Kraus STEDI-FLO™ vibratory pan feeder provides excellent performance and reliability for feeding almost any granular material from abrasive silica sand to very fine granular powders. Applications include weighing and batching where feed control is essential. It is ideal for feeding coolers, dryers, belt conveyors, bucket elevators, weigh hoppers, continuous process systems, and continuous mixers.

The STEDI-FLO vibratory pan feeder can be operated with a variable speed controller or in a fixed rate application. It is simple in design and available in a heavy-duty or light-duty construction in either mild steel, abrasion resistant steel or stainless steel. Stainless steel finishes are available in standard or polished construction.

Low Maintenance

The STEDI-FLO vibratory pan feeder requires little maintenance. The vibratory drive motors are easy to access for adjustment, when necessary.

Features:

- Rugged heavy-duty construction
- Fully enclosed vibratory motors
- Maintains constant feed rate irrespective of head load
- Welded construction for improved reliability
- Can be mounted on structure supported from below feeder
- Can be mounted from cables above feeder
- Designed to withstand exposure to all kinds of weather
- Deep sided troughs
- Full size hopper opening improves material flow
- Heavy-duty isolation springs minimize any transmitted loads
- Feeders are designed using finite element analysis
- Low frequency (900 RPM) and longer stroke minimizes implied stresses

STEDI-FLO Vibratory Pan Feeder Dimensions & Specifications

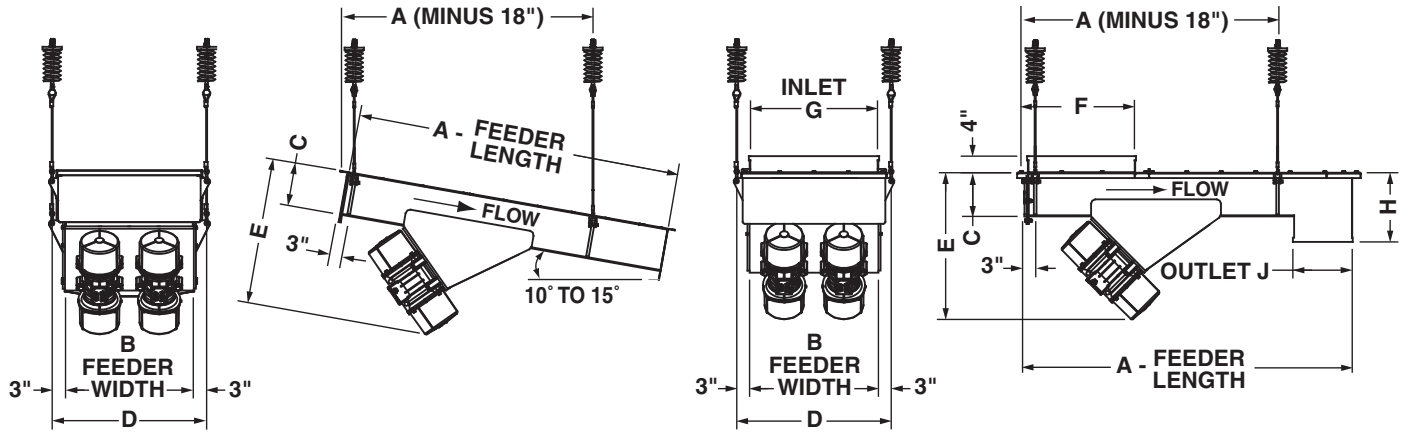

Feeder Model	STEDI-FLO Vibratory Pan Feeder Dimensions in inches (mm)										Approx. Ship Weight lbs (kg)**
	A min.	A max.	B	C	D	E*	F	G	H	J	
SE-24	48 (1219)	96 (2438)	24 (610)	10 (254)	30 (762)	36 (914)	23 (584)	23 (584)	14 (356)	8 (203)	2182 (990)
SE-30	60 (1524)	96 (2438)	30 (762)	10 (254)	36 (914)	38 (965)	29 (737)	29 (737)	14 (356)	8 (203)	2404 (1090)
SE-36	60 (1524)	96 (2438)	36 (914)	10 (254)	42 (1067)	42 (1067)	35 (889)	35 (889)	14 (356)	8 (203)	2990 (1356)
SE-42	72 (1829)	108 (2743)	42 (1067)	10 (254)	48 (1219)	44 (1118)	41 (1041)	41 (1041)	14 (356)	10 (254)	3686 (1672)
SE-48	72 (1829)	108 (2743)	48 (1219)	12 (305)	54 (1372)	46 (1168)	47 (1194)	47 (1194)	16 (406)	10 (254)	3932 (1784)
SE-54	72 (1829)	120 (3048)	54 (1372)	12 (305)	60 (1524)	50 (1270)	53 (1346)	53 (1346)	16 (406)	12 (305)	4837 (2194)
SE-60	84 (2134)	120 (3048)	60 (1524)	12 (305)	66 (1676)	56 (1422)	59 (1499)	59 (1499)	16 (406)	12 (305)	5106 (2316)

* Varies with horsepower selected. ** Weight based on maximum length.

Capacity Chart - tons per hour (metric tons per hour)

		STEDI-FLO Vibratory Pan Feeder Width in inches (mm)											
		12 (305)	18 (457)	24 (610)	30 (762)	36 (924)	42 (1067)	48 (1219)	60 (1524)	72 (1829)	84 (2134)	96 (2438)	108 (2743)
Material Bulk Density pounds per cubic foot (kilograms per cubic meter)	20 (320)	44 (40)	60 (54)	87 (79)	112 (102)	151 (137)	191 (173)	223 (202)	348 (316)	424 (385)	578 (524)	702 (637)	847 (768)
	30 (481)	62 (56)	78 (71)	121 (110)	161 (146)	216 (196)	267 (242)	313 (284)	497 (451)	602 (546)	800 (726)	994 (902)	1213 (1100)
	40 (641)	79 (72)	96 (87)	153 (139)	205 (186)	273 (248)	334 (303)	393 (357)	630 (572)	761 (690)	998 (905)	1254 (1138)	1538 (1395)
	50 (801)	96 (87)	112 (102)	181 (164)	243 (220)	324 (294)	393 (357)	463 (420)	746 (677)	902 (818)	1174 (1065)	1482 (1344)	1823 (1654)
	60 (961)	112 (102)	128 (116)	206 (187)	277 (251)	368 (334)	443 (402)	523 (474)	846 (767)	1023 (928)	1327 (1204)	1679 (1523)	2068 (1876)
	70 (1121)	127 (115)	143 (130)	229 (208)	305 (277)	405 (367)	484 (439)	572 (519)	930 (844)	1125 (1021)	1457 (1322)	1844 (1673)	2272 (2061)
	80 (1281)	141 (128)	157 (142)	249 (226)	328 (298)	436 (396)	517 (469)	611 (554)	997 (904)	1208 (1096)	1564 (1419)	1977 (1794)	2435 (2209)
	90 (1442)	154 (140)	170 (154)	265 (240)	346 (314)	459 (416)	541 (491)	640 (581)	1048 (951)	1272 (1154)	1648 (1495)	2079 (1886)	2558 (2321)
	100 (1602)	166 (151)	182 (165)	279 (253)	358 (325)	476 (432)	557 (505)	658 (597)	1082 (982)	1317 (1195)	1710 (1551)	2149 (1950)	2640 (2395)
	110 (1762)	178 (161)	194 (176)	290 (263)	366 (332)	486 (441)	564 (512)	666 (604)	1101 (999)	1344 (1219)	1748 (1586)	2188 (1985)	2682 (2433)
	120 (1922)	188 (171)	204 (185)	298 (270)	368 (334)	489 (444)	562 (510)	664 (602)	1103 (1001)	1351 (1226)	1764 (1600)	2194 (1990)	2684 (2435)
130 (2082)	198 (180)	214 (194)	303 (275)	364 (330)	485 (440)	551 (500)	651 (591)	1088 (987)	1339 (1215)	1757 (1594)	2170 (1969)	2645 (2400)	
140 (2243)	207 (188)	223 (202)	305 (277)	356 (323)	475 (431)	533 (484)	629 (571)	1058 (960)	1308 (1187)	1726 (1566)	2113 (1917)	2565 (2327)	
150 (2403)	215 (195)	231 (210)	304 (276)	342 (310)	458 (415)	505 (458)	596 (541)	1010 (916)	1258 (1141)	1673 (1518)	2025 (1837)	2445 (2218)	

Capacity based on a slope of 10 to 15 degrees.

Dimensions and specifications subject to change without notice.
Kraus Vibratory Equipment® is a registered trademark and
STEDI-FLO™ is a trademark of Dynamic Air Inc., St. Paul, Minnesota.

U.S. and Foreign Patents Pending
© 2014, Kraus Vibratory Equipment
Bulletin K020110-4 • Printed in the USA

KRAUS®
VIBRATORY EQUIPMENT
A division of Dynamic Air Inc.

Corporate Headquarters
Dynamic Air Inc. • St. Paul, MN USA • +1 651 484-2900
Worldwide Offices
Australia • Brazil • China • United Kingdom
www.dynamicaid.com • www.krausvibratory.com